

REV.	DESCRIPTION	DATE
A	NEW DRAWING	1/30/2007

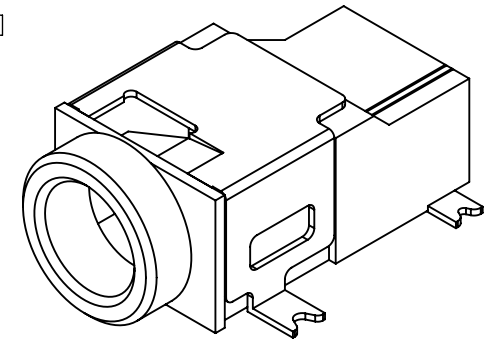

TOLERANCE:
 X.X ±0.2mm
 X.XX ±0.1mm
 X.XXX ±0.05mm

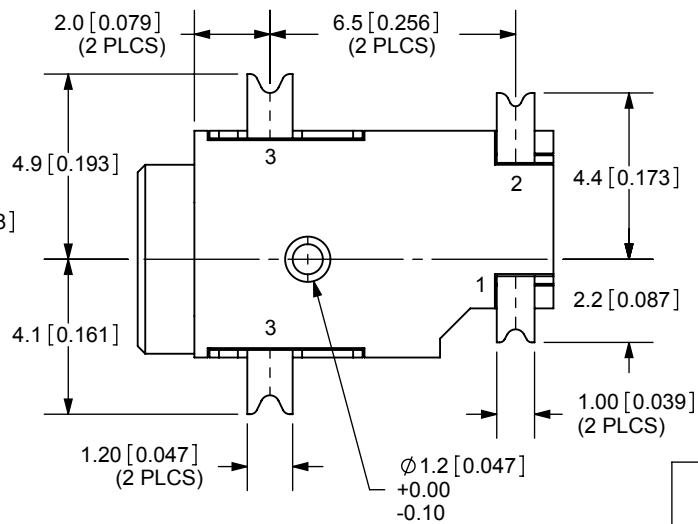
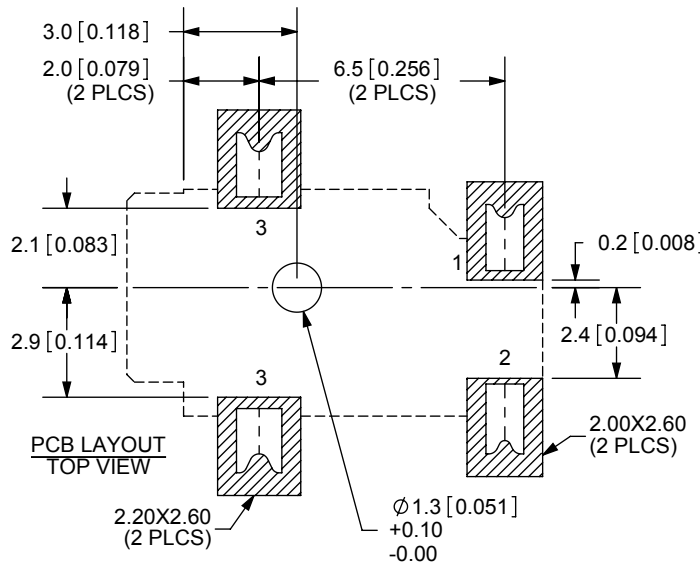
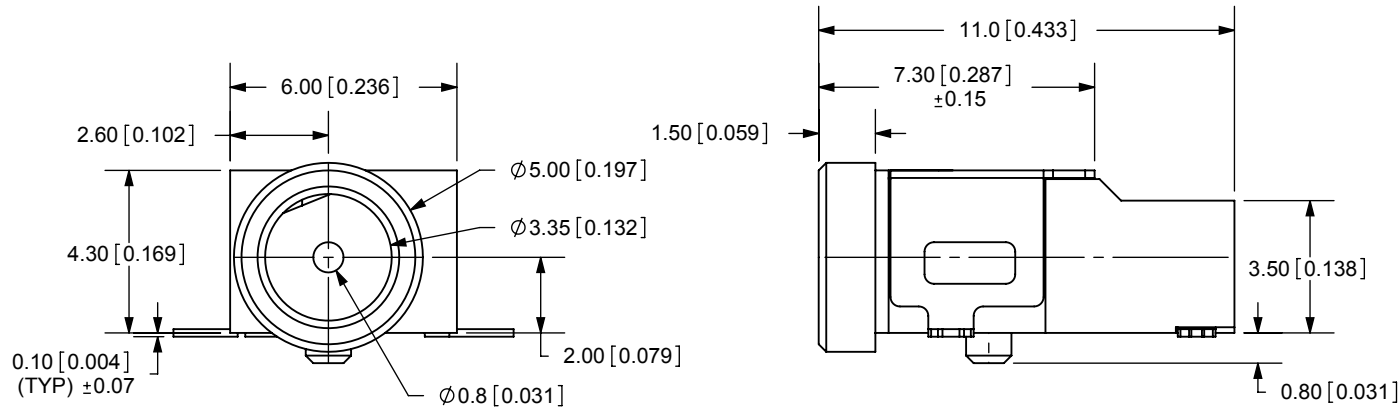

2050 SW 112th Ave.
 Tualatin, OR 97062
 Phone: 503-612-2300
 800-275-4899
 Fax: 503-612-2383
 Website: www.cui.com

SPECIFICATIONS:
 RATING: 16V DC @ 2.5A
 CONTACT RESISTANCE: 50m OHMS MAX
 INSULATION RESISTANCE: 100M OHMS MIN: 500V DC
 VOLTAGE WITHSTAND: 500V AC R.M.S. FOR 1 MINUTE
 LIFE: 5,000 CYCLES

MODEL NO.	PJ-029-SMT
SCHMATIC	

CENTER PIN DIAMETER 0.8mm Dia.

	MATERIAL	PLATING	TITLE: 0.8mm SURFACE MOUNT POWER JACK	REV: A
TERMINAL 1	Brass	Silver	PART NO. PJ-029-SMT	UNITS: MM [INCHES]
TERMINAL 2	Copper Alloy	Silver		
TERMINAL 3	Copper Alloy	Silver	DRAWN BY: ZRJ	APPROVED BY:
BODY	PA6T			

PC FILE NAME:
PJ-029-SMT

COPYRIGHT 2007 BY CUI INC.